

CURVED WALLS AND CEILINGS

INSTALLATION	378
General Requirements	378
Framing	378
CONSTRUCTION DETAILS	381

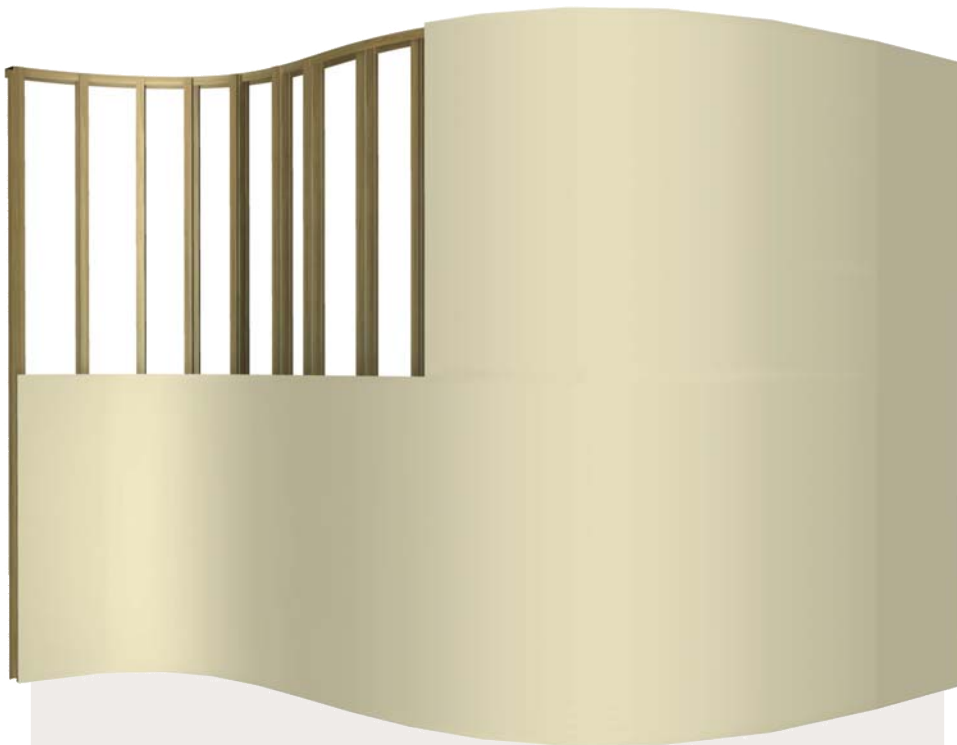

Plasterboard can be curved to create imaginative architectural effects. With careful installation and proper framing methods, tightly curved walls and ceilings are possible. Lafarge **CurveShield** is designed for this purpose and will achieve the tightest curves. All of the Lafarge Plasterboard product range can be curved if required.

This section provides details on how to bend plasterboard, including installation, framing geometry and bend radius information.

GENERAL REQUIREMENTS

Only use **CurveShield** for applications where the radius is less than 900mm.

Fix ceiling framing at 300mm maximum centres for installation of **CurveShield**.

Ensure that the radius on the convex side is not too tight for the corresponding concave side.

Stagger recessed edges and butt joints by 200mm minimum between layers.

Curve plasterboard along the short edge (widthways) for tighter radii and easier jointing.

Curve fire rated walls and ceilings to a minimum radius of 3000mm.

- i** A Rondo Flexi-Track and stud system is recommended for framing curved walls or ceilings. Avoid joints parallel to studs in the curved section. Only the face layer needs to be jointed. The minimum curve radius is determined by the concave side. A minimum of two layers of **CurveShield** is recommended.

WETTING CURVED PLASTERBOARD

Hot, humid conditions are ideal for curving plasterboard. In cold, low-humidity conditions or if very tight curves are required, prepare the plasterboard as follows:

- ▶ Use a clean paint roller or sponge to apply a small amount of water to the plasterboard surface that will be in compression. Add a small amount of detergent to the water in very dry conditions to act as a wetting agent.
- ▶ Allow at least 15 minutes for the water to soak in before bending the plasterboard.

FRAMING

MAXIMUM FRAME SPACING AND MINIMUM CURVE RADIUS FOR CURVESHIELD

	CURVE RADIUS (mm)									
	250-450	450-650	650-900	900-1000	1000-1500	1500-2000	2000-2500	2500-3000	3000-4000	> 4000
	MAXIMUM FRAMING CENTRES (mm)									
Concave CurveShield . Curved along length.	-	-	200	200	200	250	300	350	450	550
Convex CurveShield . Curved along length.	-	200	200	200	200	250	300	350	450	550
Concave CurveShield . Curved along width.	-	150	150	150	200	250	300	350	450	550
Convex CurveShield . Curved along width.	125	150	150	150	200	250	300	350	450	550

MAXIMUM FRAME SPACING AND MINIMUM CURVE RADIUS FOR OTHER PLASTERBOARD

PLASTERBOARD THICKNESS	MastaShield ONLY				ALL PLASTERBOARD EXCEPT AcoustiShield *			
	CURVE RADIUS (mm)							
	900-1000	1000-1500	1500-2000	2000-2500	2500-3000	3000-4000	> 4000	
	MAXIMUM FRAMING CENTRES (mm)							
10mm	150	200	250	300	350	400	500	
13mm	-	150	200	250	300	400	500	
16mm	-	-	-	-	200	250	350	

* **AcoustiShield** has a minimum curve radius of 5000mm

FIGURE 1
Concave wall
 Horizontal (curved lengthways)

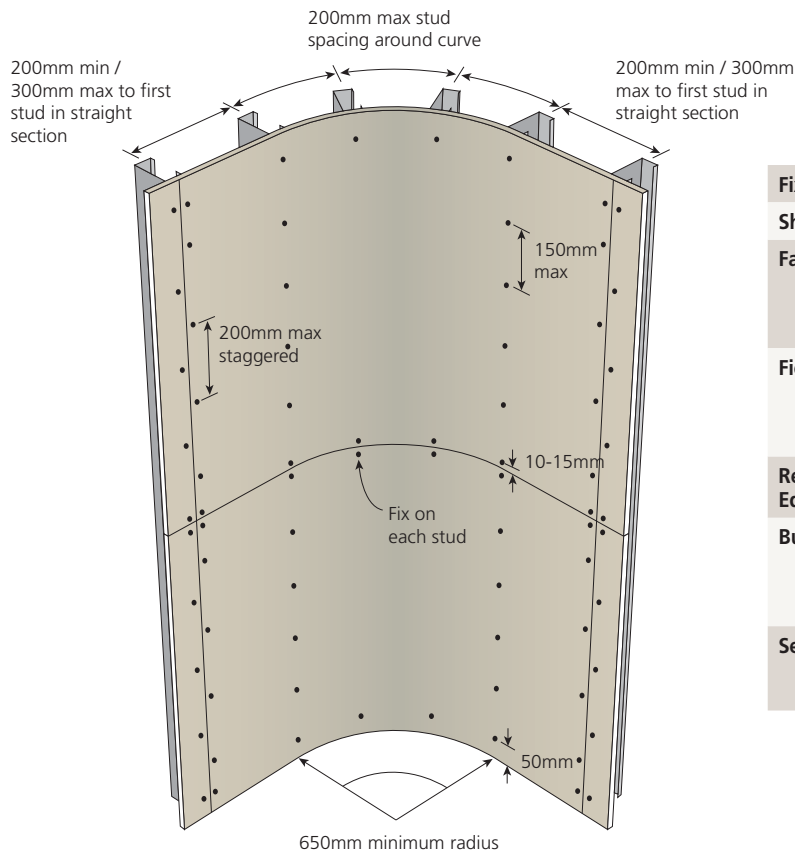

Fixing	SCREW ONLY METHOD
Sheet Layout	Horizontal.
Fasteners	Perimeter screws 10-15mm from sheet edges except at top and bottom tracks. Plasterboard must not be fixed to top and bottom tracks.
Field	Fix at 150mm max centres on straight sections. Do not fix screws on the field of the plasterboard in the curved section.
Recessed Edges	Fix on each stud. Stagger recessed edges by 300mm min between layers.
Butt Joints	Fix at 200mm max centres and stagger screws. Stagger butt joints by 300mm between layers and on opposite sides of the wall.
Sealant	Use sealant on all gaps and around perimeter to maintain acoustic integrity. [REFER TO CONSTRUCTION DETAILS]

FIGURE 2
Concave wall
 Vertical (curved widthways)

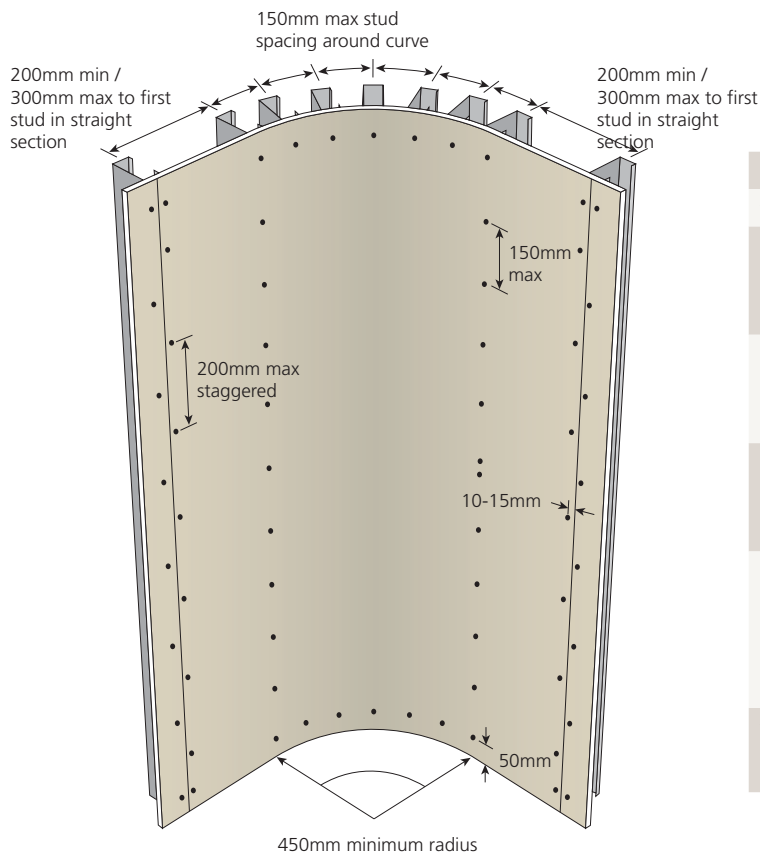

Fixing	SCREW ONLY METHOD
Sheet Layout	Vertical.
Fasteners	Perimeter screws 10-15mm from sheet edges except at top and bottom tracks. Plasterboard must not be fixed to top and bottom tracks.
Field	Fix at 150mm max centres on straight sections. Do not fix screws on the field of the plasterboard in the curved section.
Recessed Edges	Fix at 200mm max centres and stagger screws. Stagger recessed edges by 300mm min between layers and on opposite sides of the wall.
Butt Joints	Fix at 200mm max centres and stagger screws. Stagger butt joints by 600mm min between layers, on adjoining sheets and on opposite sides of the wall. 1st layer butt joints must be backed by a nogging or back-blocked.
Sealant	Use sealant on all gaps and around perimeter to maintain acoustic integrity. [REFER TO CONSTRUCTION DETAILS]

FIGURE 3
Convex wall
Horizontal (curved lengthways)

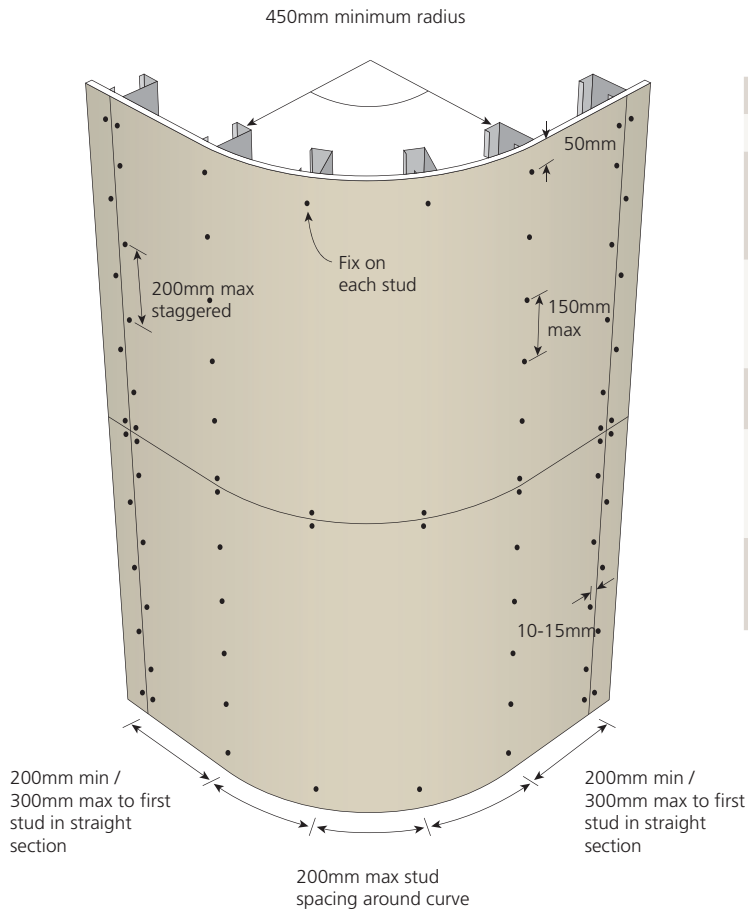

Fixing	SCREW ONLY METHOD
Sheet Layout	Horizontal.
Fasteners	Perimeter screws 10-15mm from sheet edges except at top and bottom tracks. Plasterboard must not be fixed to top and bottom tracks.
Field	Fix at 150mm max centres on straight sections. Do not fix screws on the field of the plasterboard in the curved section.
Recessed Edges	Fix on each stud. Stagger recessed edges by 300mm min between layers.
Butt Joints	Fix at 200mm max centres and stagger screws. Stagger butt joints by 300mm between layers and on opposite sides of the wall.
Sealant	Use sealant on all gaps and around perimeter to maintain acoustic integrity. [REFER TO CONSTRUCTION DETAILS]

FIGURE 4
Convex wall
Vertical (curved widthways)

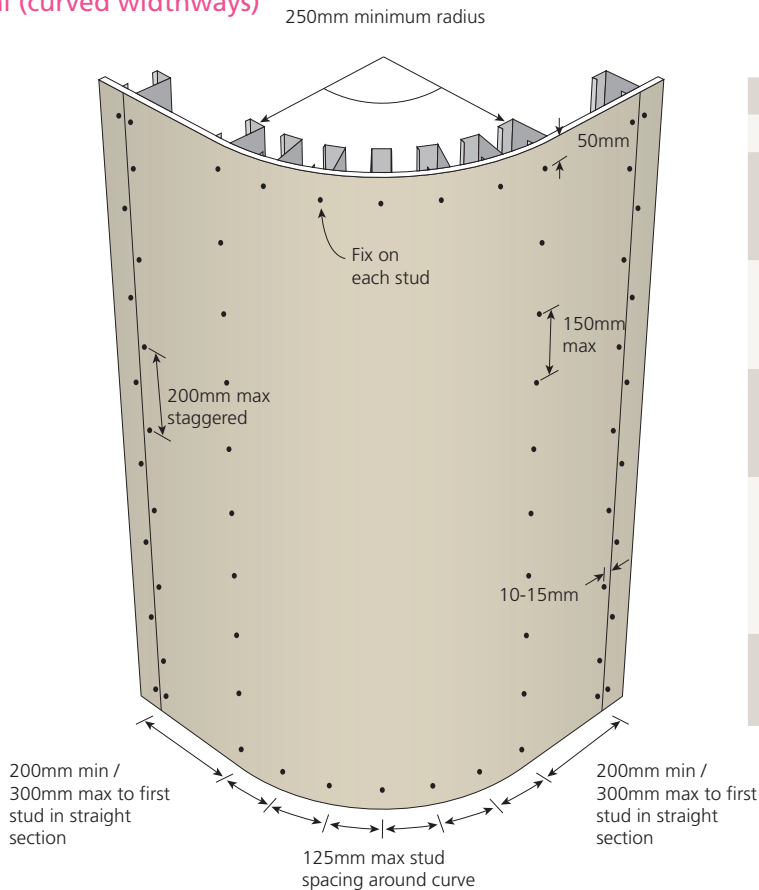

Fixing	SCREW ONLY METHOD
Sheet Layout	Vertical.
Fasteners	Perimeter screws 10-15mm from sheet edges except at top and bottom tracks. Plasterboard must not be fixed to top and bottom tracks.
Field	Fix at 150mm max centres on straight sections. Do not fix screws on the field of the plasterboard in the curved section.
Recessed Edges	Fix at 200mm max centres and stagger screws. Stagger recessed edges by 300mm min between layers and on opposite sides of the wall.
Butt Joints	Fix at 200mm max centres and stagger screws. Stagger butt joints by 600mm min between layers, on adjoining sheets and on opposite sides of the wall. 1st layer butt joints must be backed by a nogging or back-blocked.
Sealant	Use sealant on all gaps and around perimeter to maintain acoustic integrity. [REFER TO CONSTRUCTION DETAILS]

NON-FIRE RATED
CURVED WALL AND CEILING DETAIL

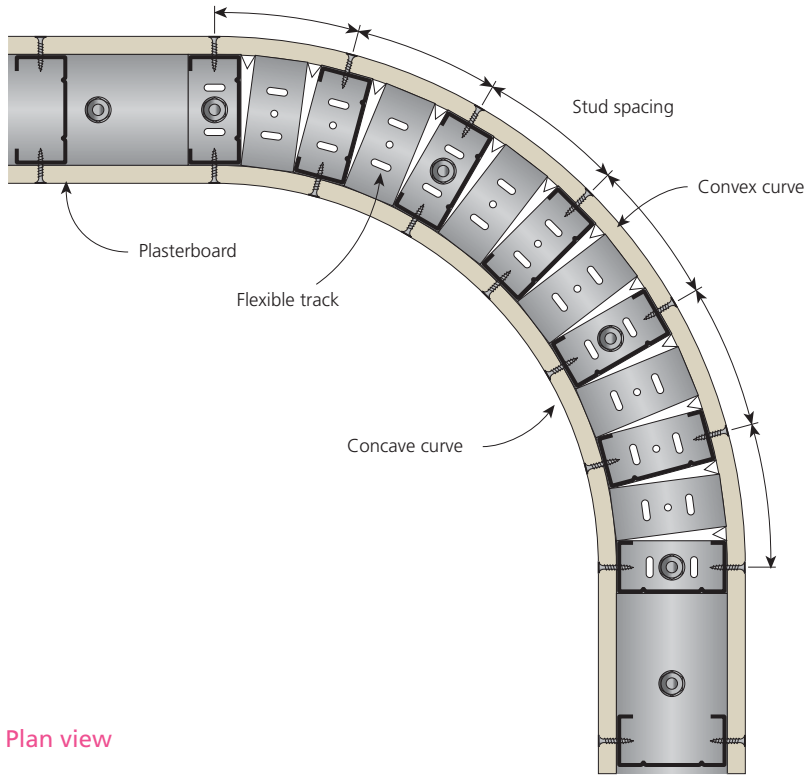

FIGURE 5
Curved wall - Plan view

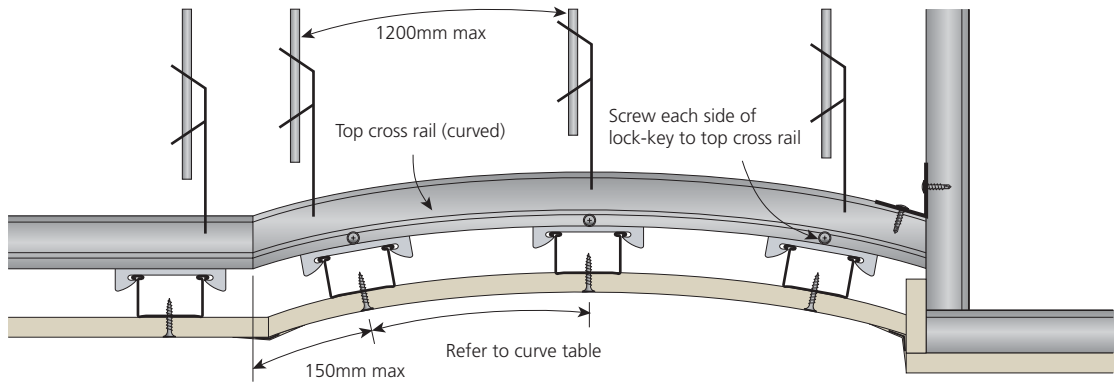

FIGURE 6
Curved suspended ceiling - Elevation

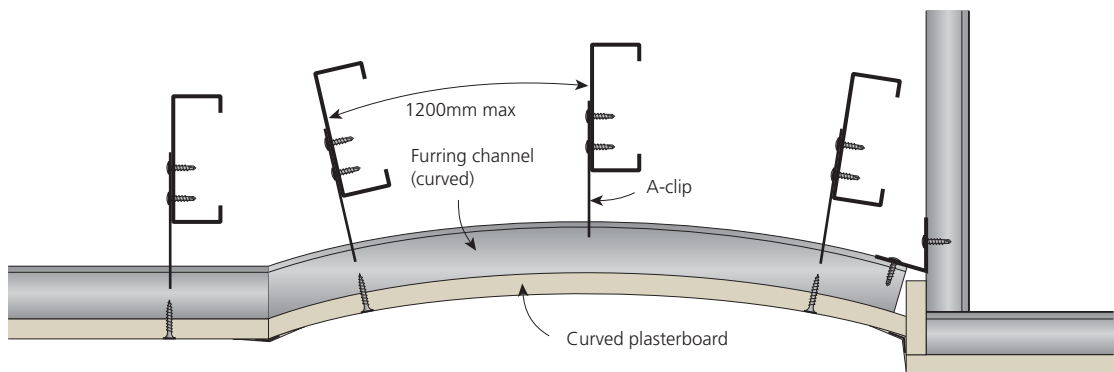

FIGURE 7
Curved ceiling - Elevation